

Tubline



Surface Mounted Facade & Landscape Luminary



Luminaire Group	Facade & Landscape
Mounting Type	Surface Mounted
Housing	Polycarbonate
Optics	Polycarbonate Acrylic
Light Source	LED
Electrical Protection Class	CLASS II
IP	65
IK	02
Operating Temperature	-20°C / +40°C
Luminous Flux	869 lm
Consumption Power	12 W
Luminaire Efficiency	69 lm/W
Color Rendering (CRI)	>80
Light Color Temperature (CCT)	2700K / 3000K / 4000K / 6500K
Color Tolerance	< 3 SDCM
Driver Type	On/Off
Driver Brand	Tridonic
LED Brand	Samsung
Input Voltage / Frequency	220-240 V AC 50/60 Hz
Power Factor	>0.9
Surge	1kV
THD (AKIM)	>%20
LED life	>70.000 hours
Option	On-Off / Dali / 1-10V

Technical Drawing

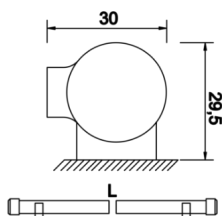

SKU	Product Code	Power (W)	Luminous Flux (LM)	CRI	CCT (K)	Optics	Dimensions (mm)
	TUB 002 100 0012S 8040 10 99 OP 65 00	12	869	>80	4000	180° Polycarbonate Acrylic	Ø30mm L:1000□□