

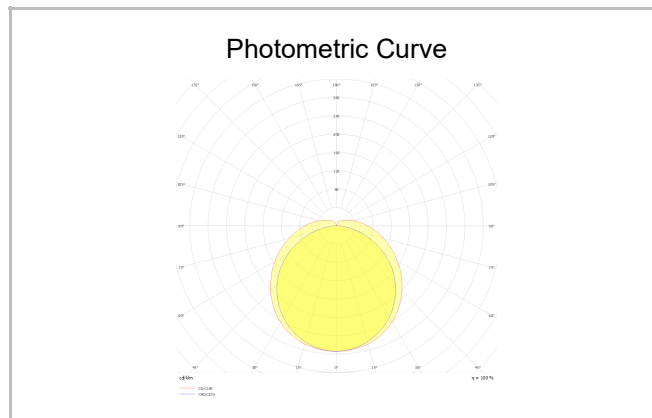

Luminaire Group	Wood & Concrete Products
Mounting Type	Pendant
Luminary Color	
Housing	Wood
Optics	Opal Diffuser
Light Source	LED
Electrical Protection Class	CLASS II
IP	20
IK	02
Operating Temperature	-20°C / +40°C
Luminous Flux	3744 lm
Consumption Power	26 W
Luminaire Efficiency	144 lm/W
Color Rendering (CRI)	>80
Light Color Temperature (CCT)	2700K/3000K/4000K/6500K
Color Tolerance	< 3 SDCM
Driver Type	On/Off
Driver Brand	Tridonic
LED Brand	Samsung
Input Voltage / Frequency	220-240 V AC 50/60 Hz
Power Factor	>0.9
Surge	1kV
THD (AKIM)	>%20
LED life	>70.000 hours
Option	On-Off / Dali / 1-10V / With Emergency Kit

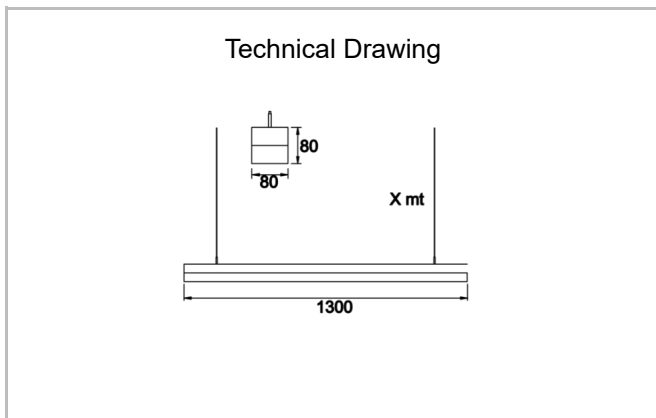

SKU	Product Code	Power (W)	Luminous Flux (LM)	CRI	CCT (K)	Optics	Dimensions (mm)
	MGR 100 080 026P 8040 10 99 OP 20 00	26	3744	>80	4000	120° Opal Diffuser	1300x80x80